



D-STAR

How it works

Icom America Inc.

TSR

How To Program Your D-STAR Radio



Understanding how it works

D-STAR utilizes call signs to “route” the radio call.

Every repeater must be assigned a unique call sign (club call recommended).

Every owner / operator programs their radio with their own call sign.

Call sign is transmitted digitally with each transmission.

No need to voice ID with D-STAR since digital ID is part of each TX.

Understanding how it works

Each radio has 4 call sign fields to be programmed. What you need to know to program a radio is:

Operating frequency	Simplex or Duplex frequency
MyCall	Your call sign (primary operator)
UrCall	Call sign of the person / zone being called
Rpt1	1 st repeater
Rpt2	2 nd repeater

Understanding how it works (Simplex)

To complete a local simplex call, program 2 fields along with the frequency in the radio.

MyCall

UrCall

My call sign (eg. KK9H)

Your call sign or "CQCQCQ"

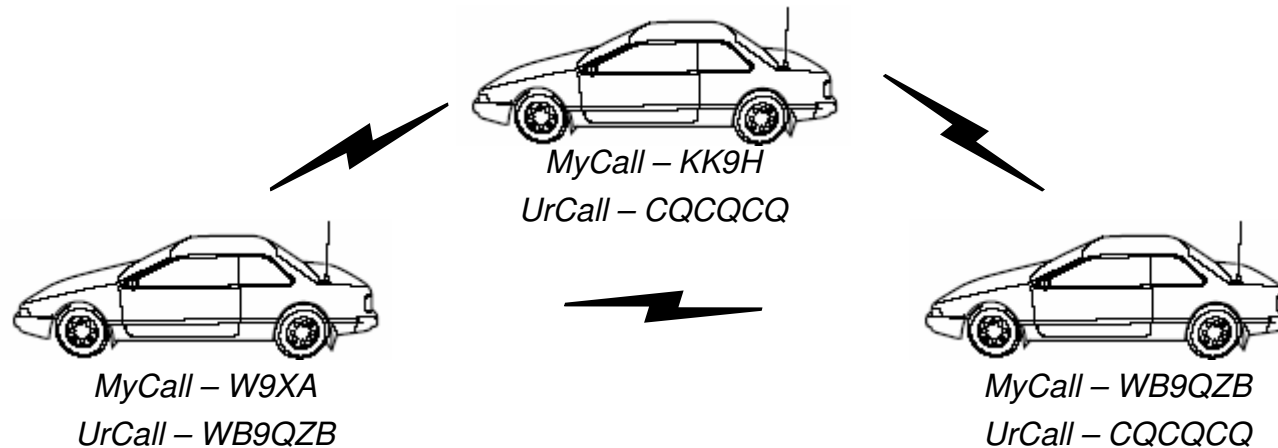

Understanding how it works (Simplex)

In this example, all parties in digital mode hear all the traffic on the simplex channel.

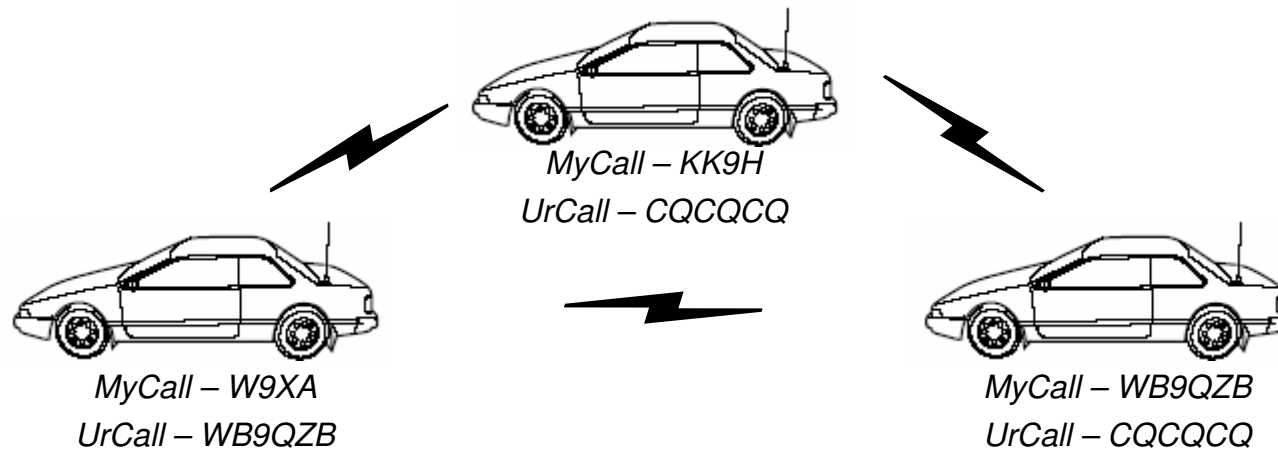

Understanding how it works (Repeater)

To complete a local zone repeater call, program 3 fields along with the frequency in the radio.

MyCall	My call sign (eg. KK9H)
UrCall	Your call sign or "CQCQCQ"
Rpt1	Local repeater call sign

Understanding how it works (Repeater)

When you program your radio's "RP1" location, and the proper frequency, your radio tells the desired repeater to activate. This is similar to PL tones in analog.

Eg. MyCall	KK9H
RPT1	NS9RC A
UrCall	CQCQCQ
RPT2	nothing

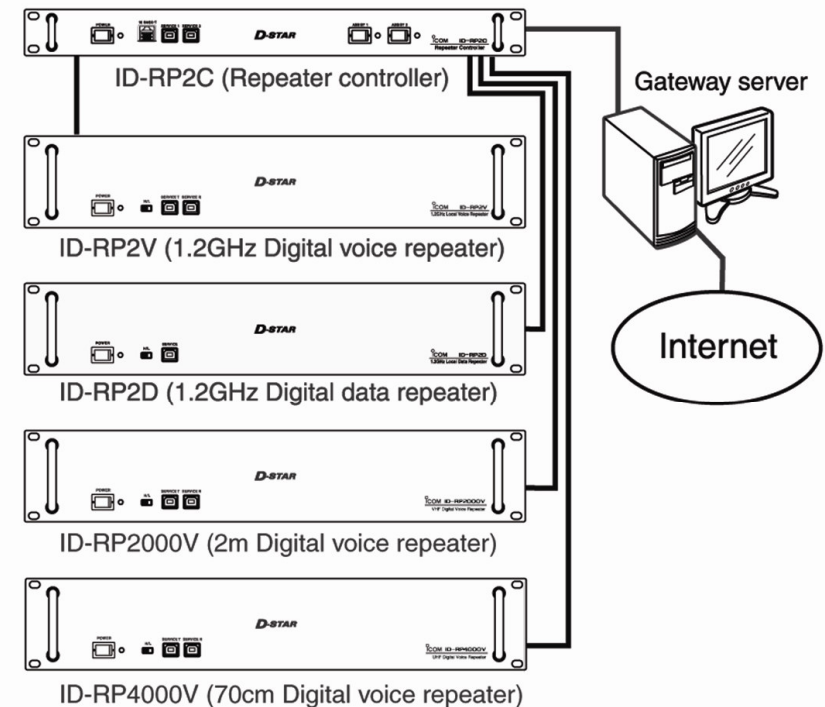

Up to 4 repeaters can be connected to 1 ID-RP2C

NS9RC Repeater

Understanding how it works (Repeater)

Eg. MyCall	KK9H
RPT1	NS9RC A
UrCall	CQCQCQ
RPT2	nothing

In this example, the NS9RC repeater would activate on the repeater frequency you were transmitting on (1.2GHz).

(In this example, we are using the ID-1 radio.)

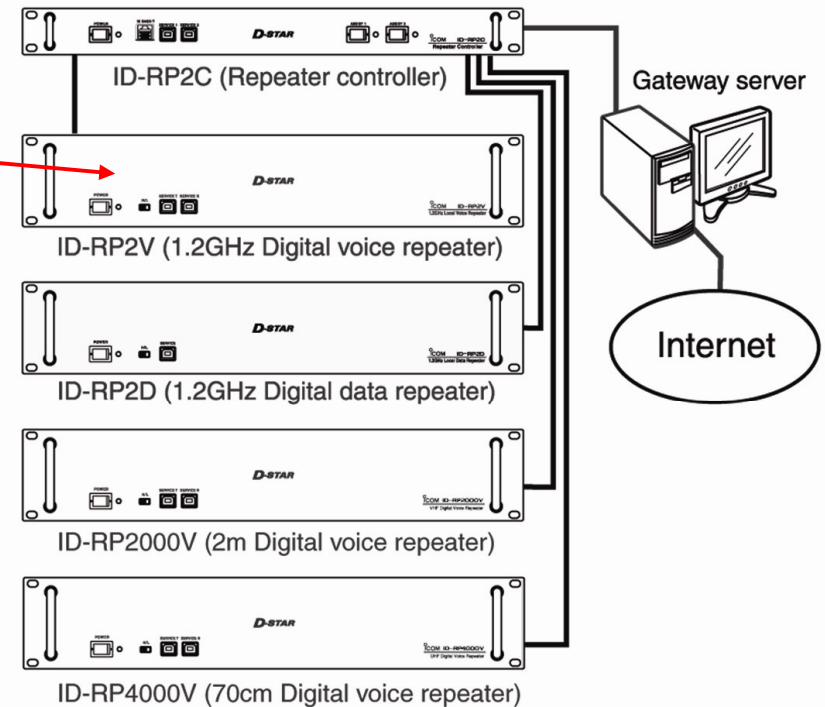

Up to 4 repeaters can be connected to 1 ID-RP2C

NS9RC Repeater

Understanding how it works (Repeater)

All parties on the local repeater channel will hear all the local radio traffic on that frequency.

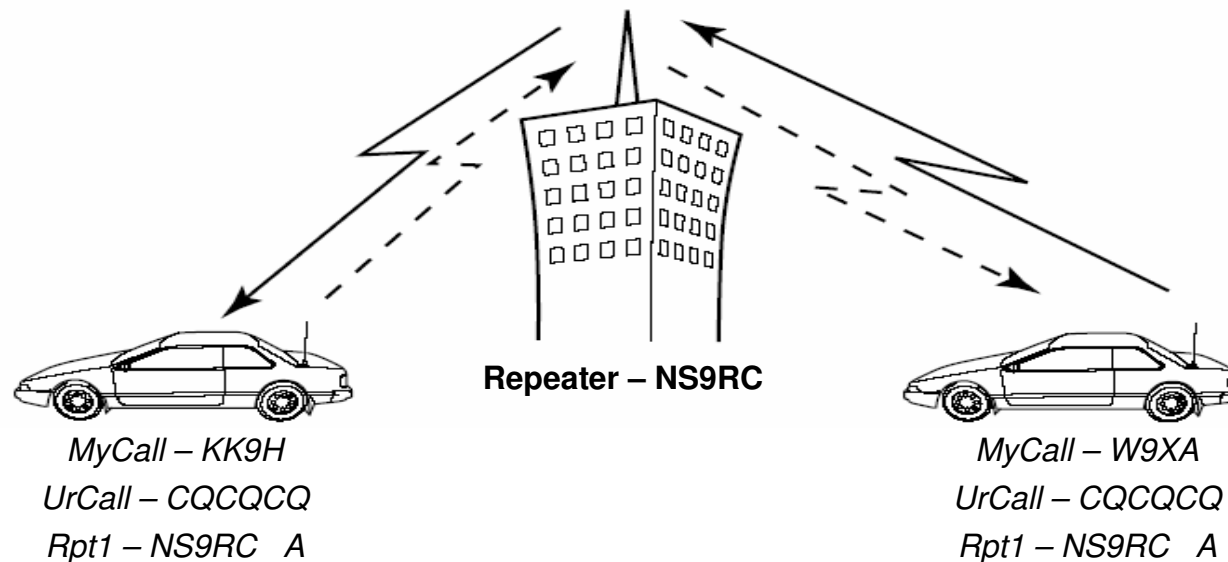

Understanding how it works (Gateway)

To complete a gateway repeater call, program all 4 call sign fields within the radio.

Repeater must be connected to a gateway server PC.

MyCall	My call sign (eg. KK9H)
UrCall	Your call sign or “/ zone” and module (eg. /W9CEQ A)
Rpt1	Local repeater call sign
Rpt2	Local repeater + “G” as the 8 th letter (eg. NS9RC G)

Understanding how it works (Repeater)

Eg. MyCall KK9H
RPT1 **NS9RC A**
 UrCall /W9CEQ
 RPT2 NS9RC G

In this example, the NS9RC repeater would activate on the repeater frequency you were transmitting (1.2GHz) and then...

(In this example, we are using the ID-1 radio.)

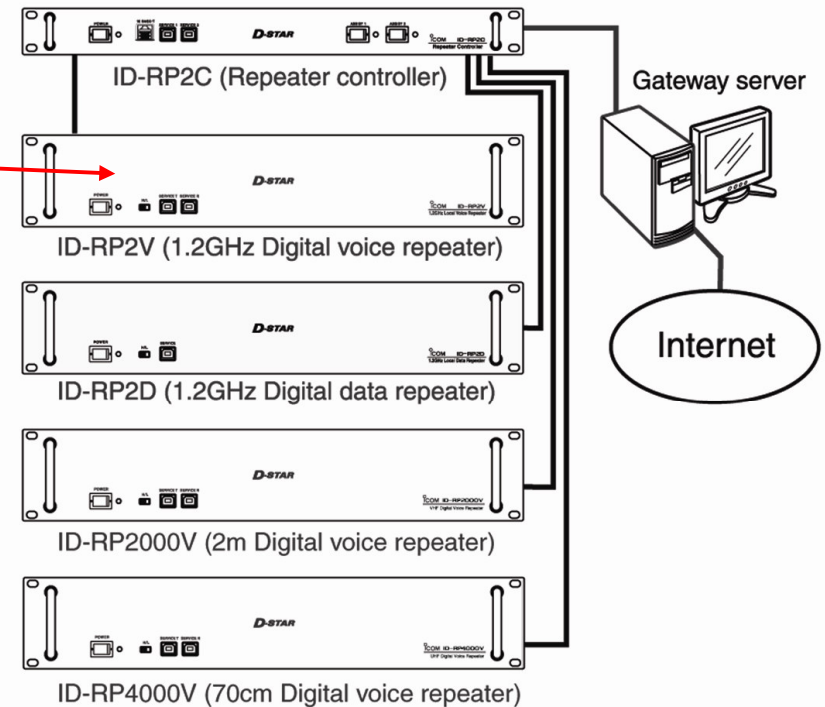

Up to 4 repeaters can be connected to 1 ID-RP2C

NS9RC Repeater

Understanding how it works (Repeater)

Eg.

MyCall	KK9H
RPT1	NS9RC
UrCall	/W9CEQ
RPT2	NS9RC

routed to the gateway and directed to the proper remote repeater through the internet.

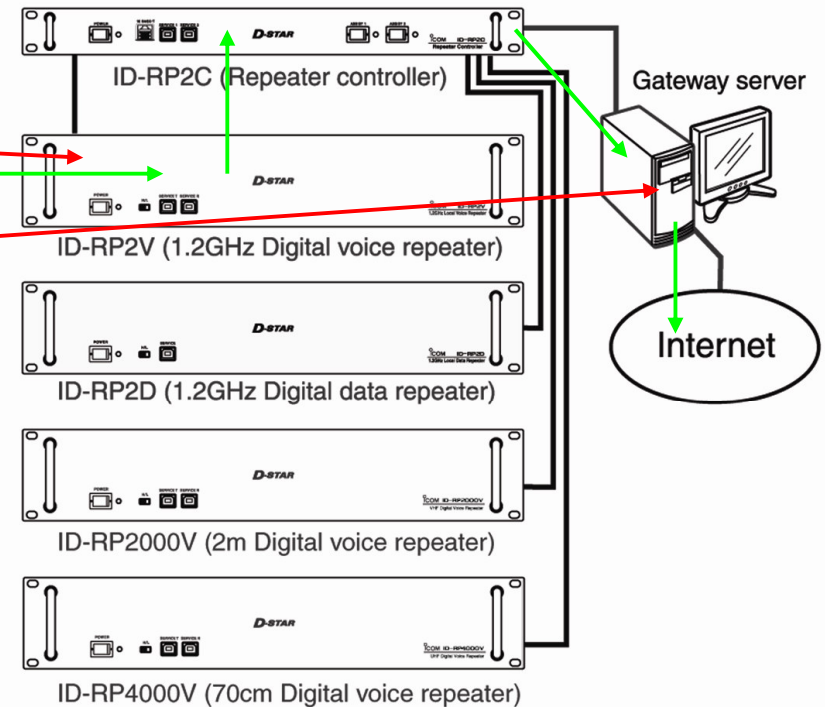

Up to 4 repeaters can be connected to 1 ID-RP2C

NS9RC Repeater

Understanding how it works (Repeater)

Eg. MyCall KK9H
 RPT1 NS9RC A
 UrCall /**W9CEQ**
 RPT2 NS9RC G

The gateway is told where to route the call based on what is in the “UrCall” field of the radio.

/W9CEQ tells the gateway to route the call to the W9CEQ repeater. The “/” means “zone call”.

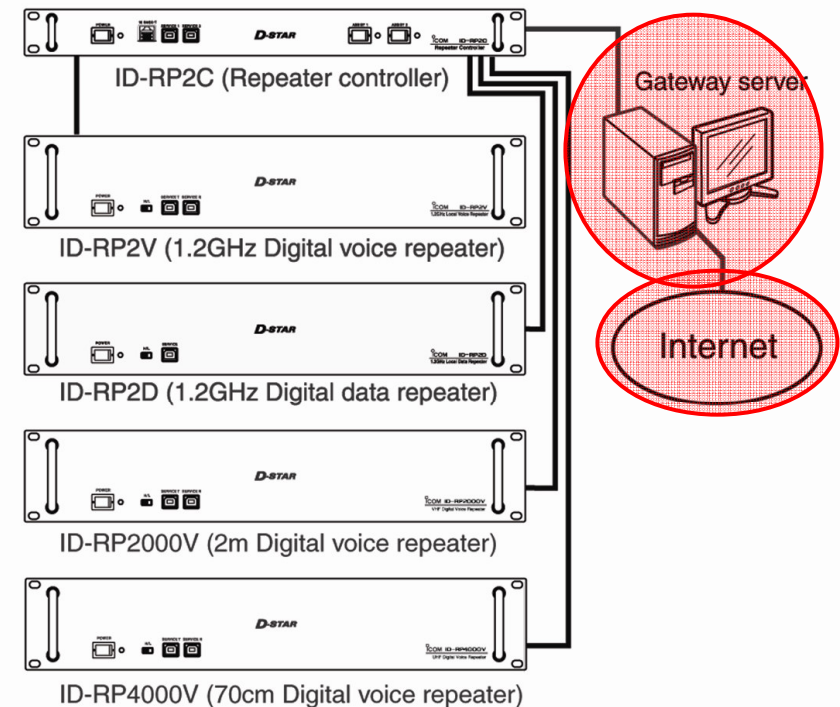

Up to 4 repeaters can be connected to 1 ID-RP2C

NS9RC Repeater

Understanding how it works (Gateway)

Using “/” in front of the repeater call sign in the “UrCall” field activates that “zone” (module) at the remote repeater.

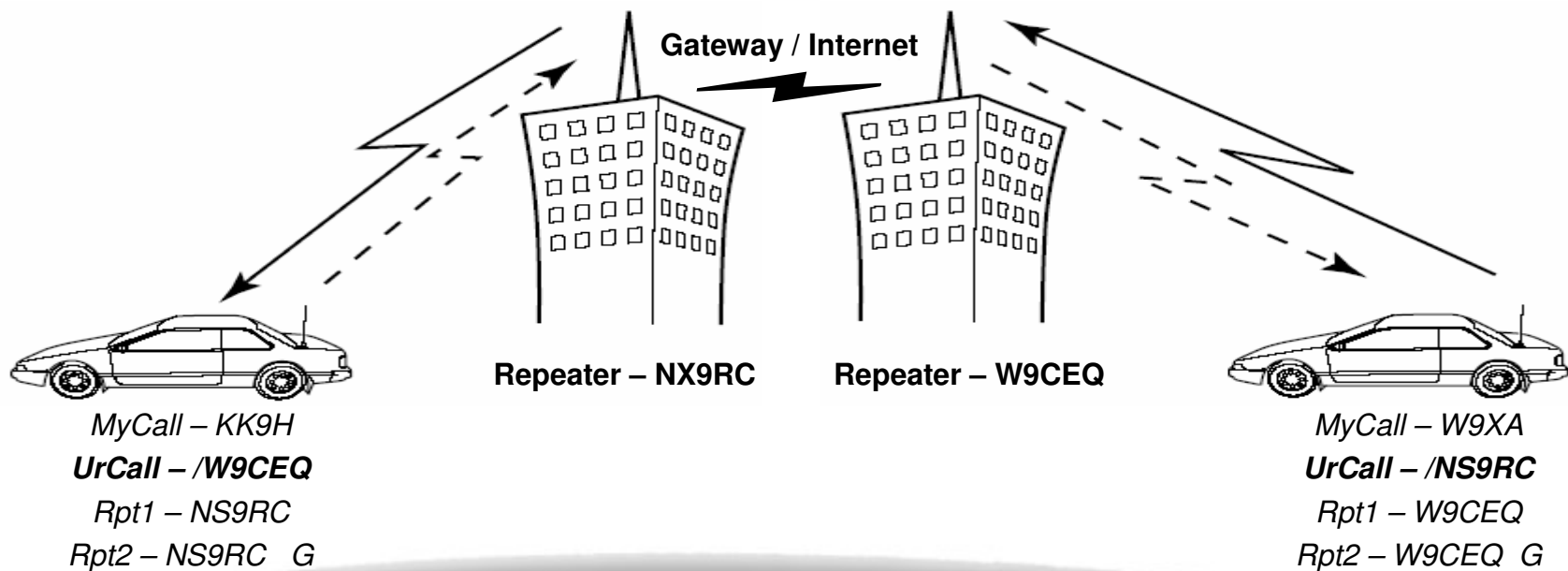

Understanding how it works (Repeater)

Eg. MyCall KK9H
 RPT1 NS9RC A
UrCall /W9CEQ ?
 RPT2 NS9RC G

Since we did not designate a “module” in the “UrCall” field, the system automatically routes to the “A” module of the remote repeater (W9CEQ).

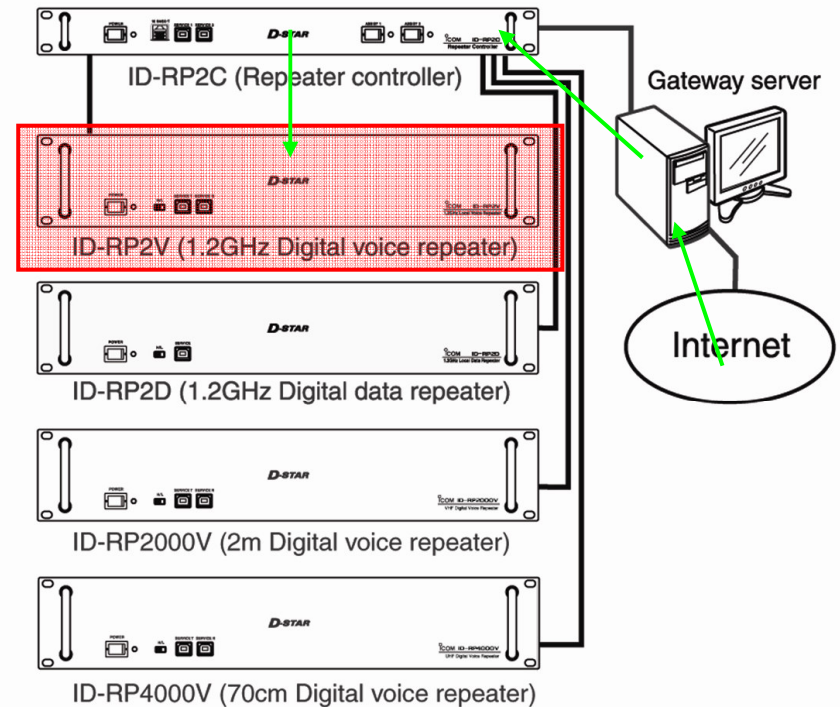

Up to 4 repeaters can be connected to 1 ID-RP2C

W9CEQ Repeater

Understanding how it works (Repeater)

Eg. MyCall KK9H
 RPT1 NS9RC A
UrCall /W9CEQ B
 RPT2 NS9RC G

If we add the “designator” as the 8th letter, we can route to different modules at the remote repeater site.

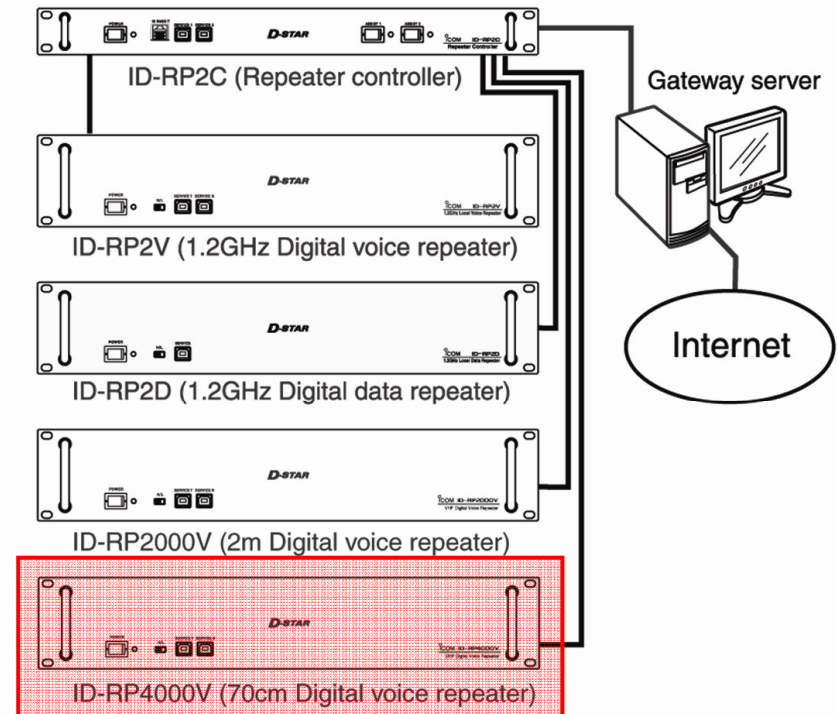

Up to 4 repeaters can be connected to 1 ID-RP2C

W9CEQ Repeater

Understanding how it works (Repeater)

Eg. MyCall KK9H
 RPT1 NS9RC A
UrCall /W9CEQ
 RPT2 NS9RC G

Currently, you are *not able* to activate more than 1 module at the remote repeater site.

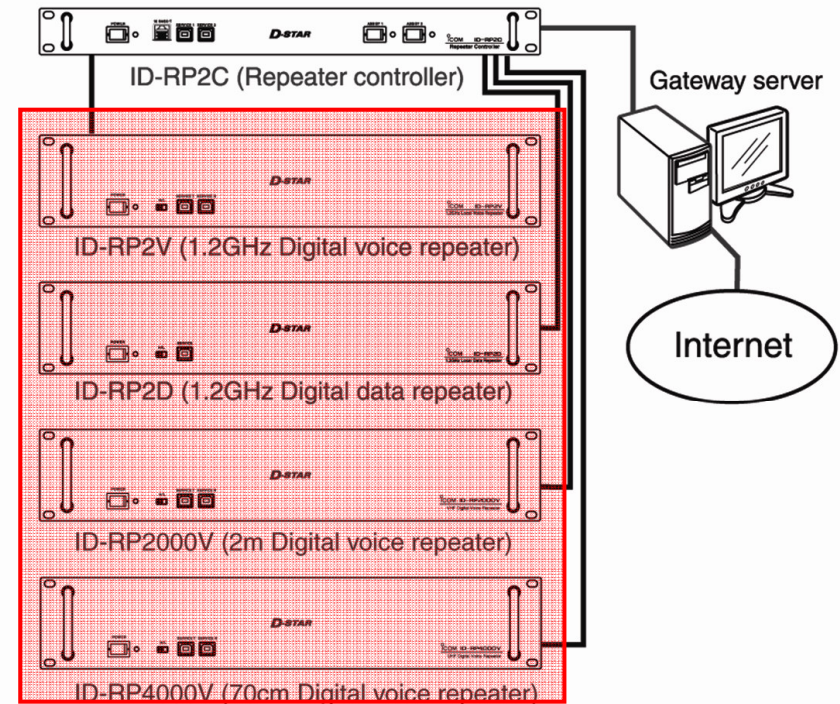

Up to 4 repeaters can be connected to 1 ID-RP2C

W9CEQ Repeater

Understanding how it works (Repeater)

Eg. MyCall KK9H
 RPT1 NS9RC A
 UrCall **W9XA**
 RPT2 NS9RC G

If you use the call sign of the person you wish to call, the gateway automatically routes the call to the last known location of that call sign within the repeater network.

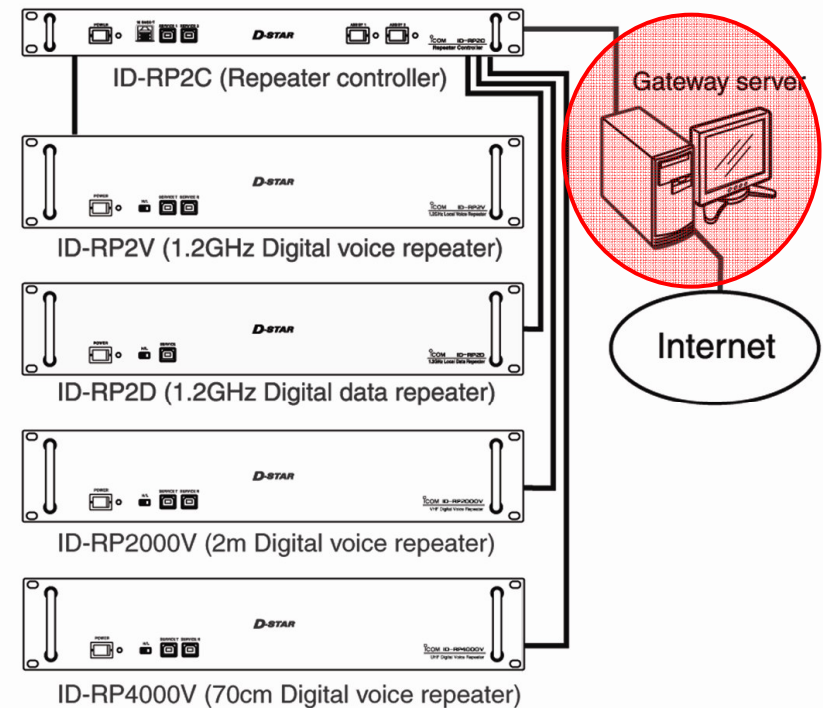

Up to 4 repeaters can be connected to 1 ID-RP2C

NS9RC Repeater

Understanding how it works (Gateway)

Using the call sign of the desired party to be reached in the “UrCall” field automatically routes to wherever the radio was last heard.

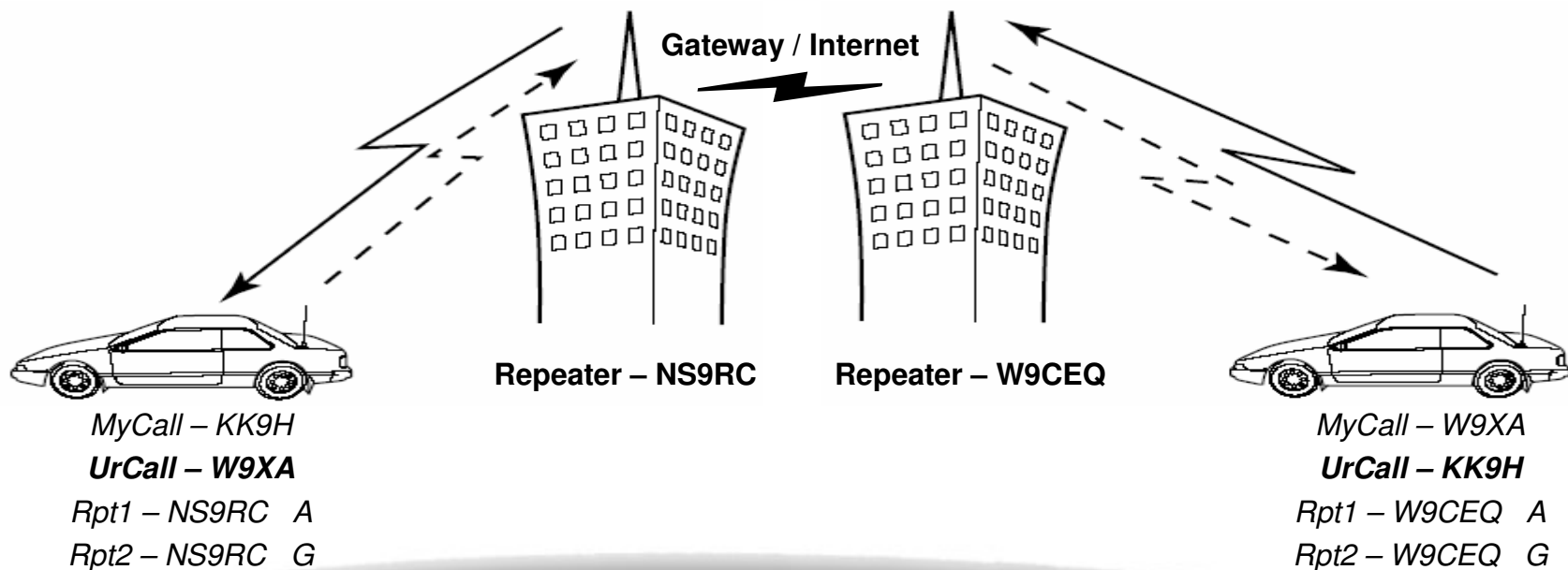

Understanding how it works (Gateway)

In both examples, all parties on the local repeater and remote repeater hear all the radio traffic on the frequency.

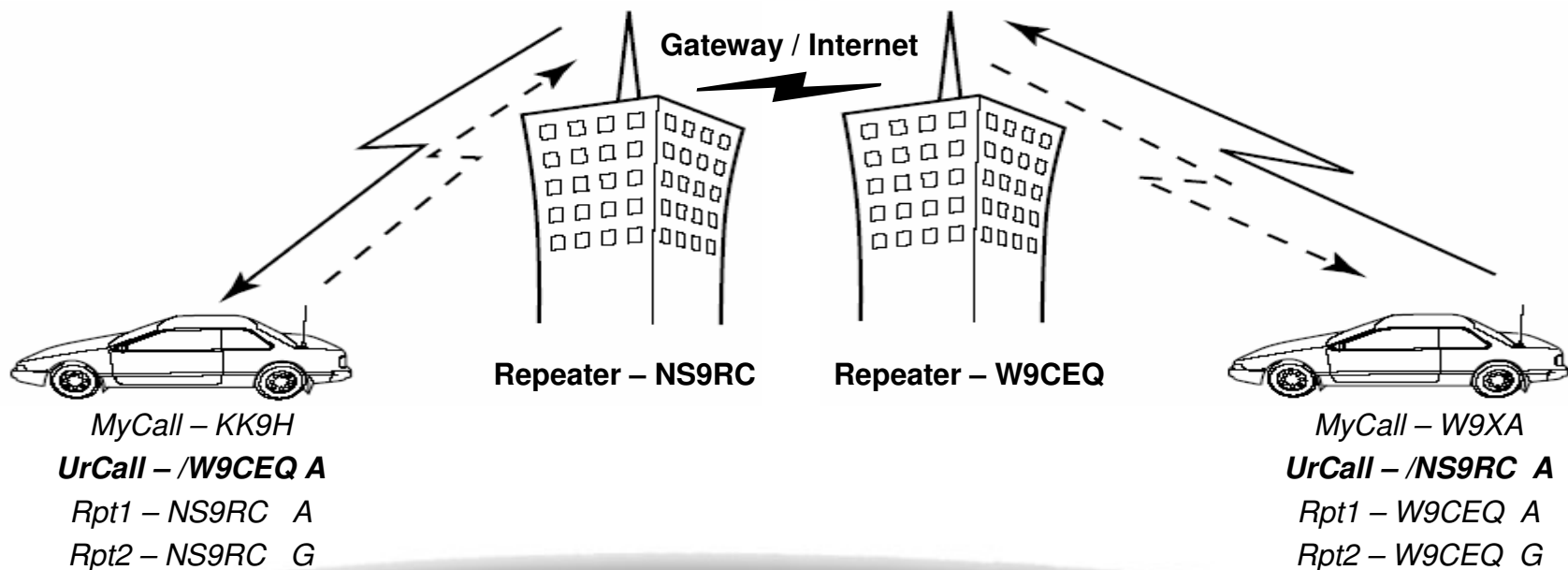

Understanding how it works (Gateway)

Both radios must be properly programmed to operate via the gateway in order for transmissions to be heard both directions.

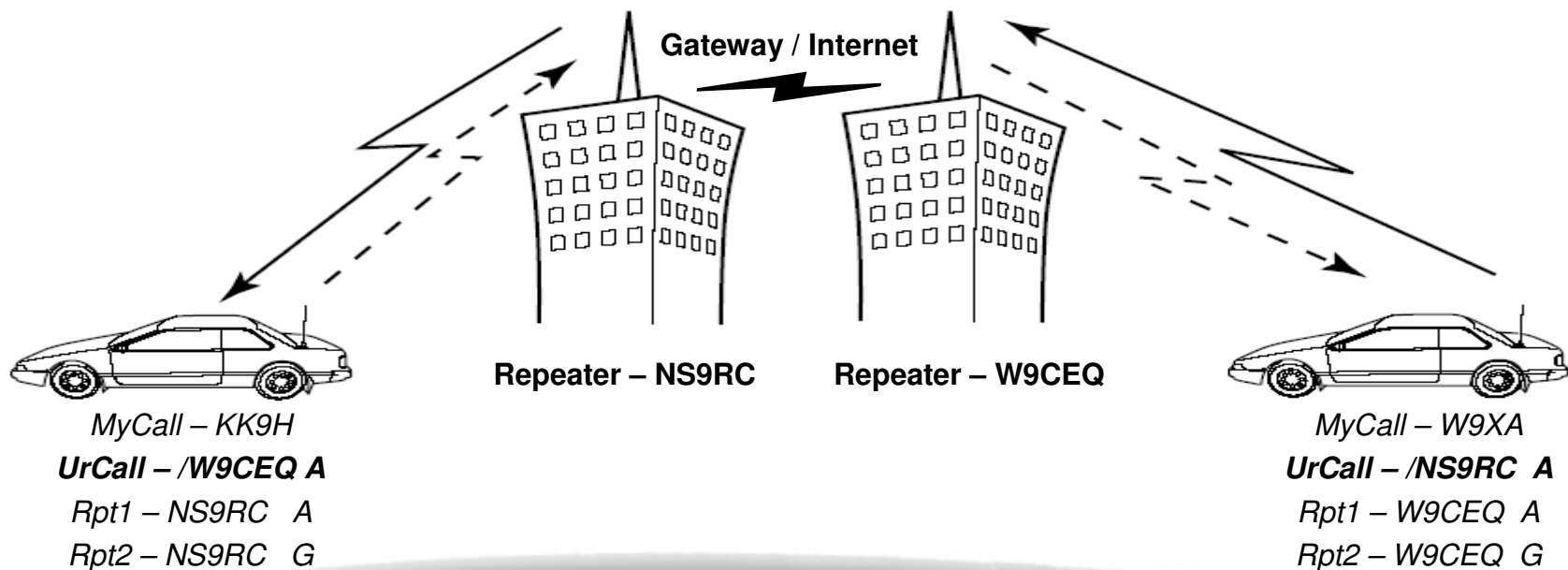

Understanding how it works (Gateway)

In this example, W9XA would hear KK9H's transmission but, KK9H would not hear W9XA since no gateway is selected.

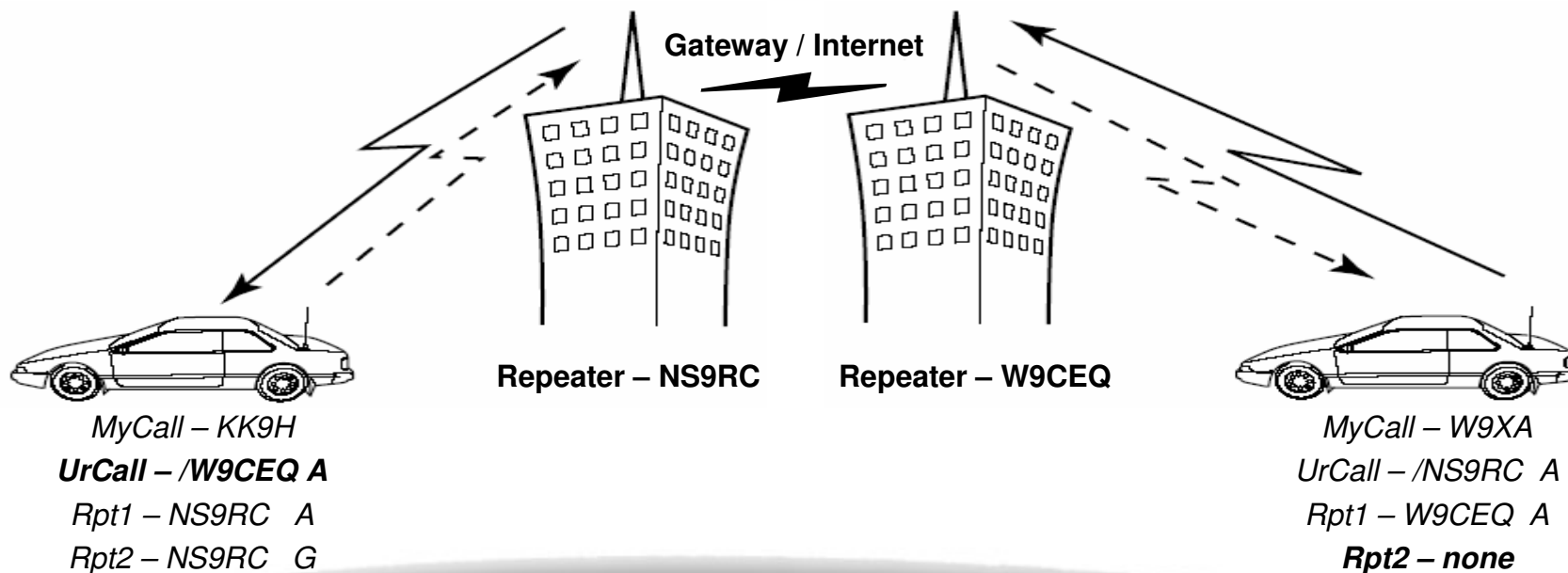

Understanding how it works (Repeater)

To complete a cross-band (*cross-module*) repeater call, program all 4 call sign fields within the radio. Repeater must have multiple voice modules installed.

MyCall	My call sign (eg. KK9H)
UrCall	Your call sign or "CQCQCQ"
Rpt1	Local repeater input module call sign (eg. NS9RC A)
Rpt2	Local repeater output module as the 8 th letter (eg. NS9RC B)

Signal is repeated on both input and output frequencies / modules locally.

Understanding how it works (Repeater)

Eg.

MyCall	KK9H
RPT1	NS9RC A
UrCall	CQCQCQ
RPT2	NS9RC B

When using the designator of another local module in the "RPT2" field, the call is routed to that module locally.

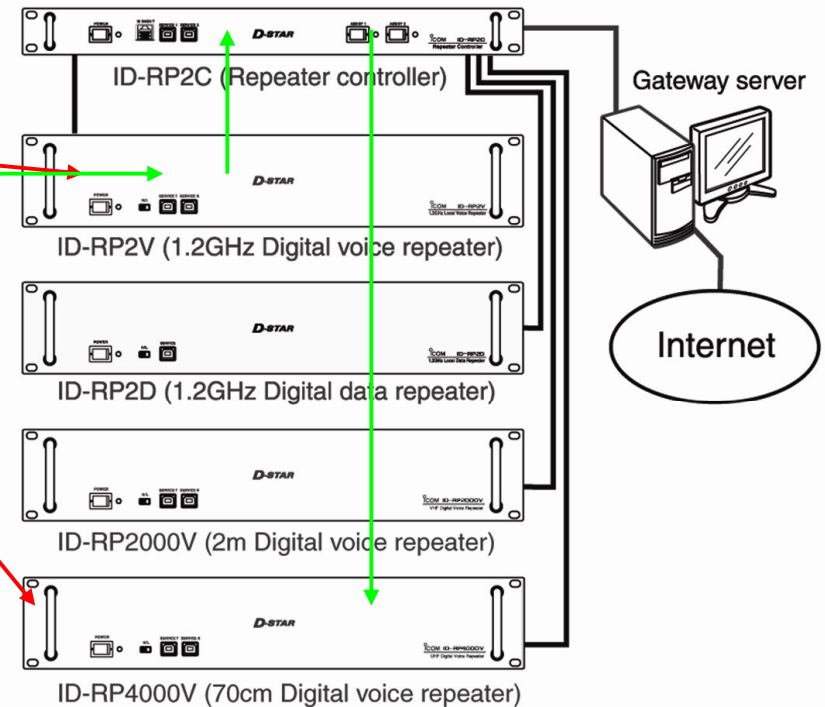

Up to 4 repeaters can be connected to 1 ID-RP2C

NS9RC Repeater

Understanding how it works (Repeater)

In this example, all parties listening on 1.2GHz and 440MHz would hear all radio traffic.

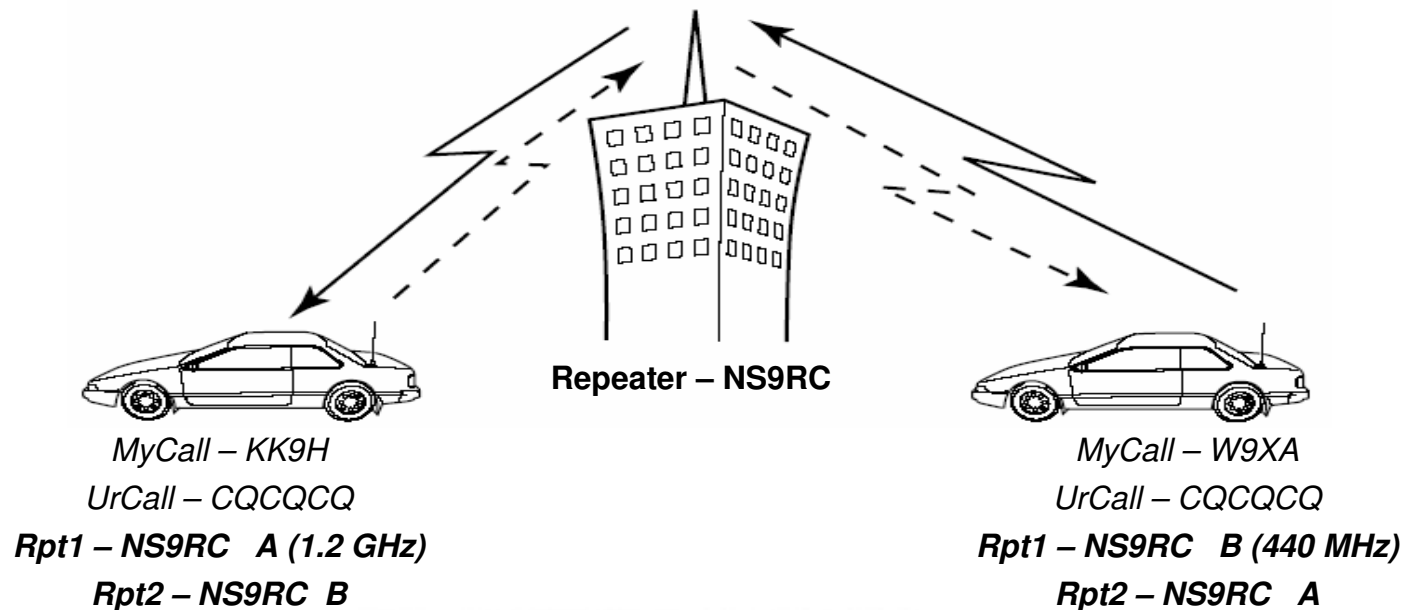

Understanding how it works (Repeater)

In this example, KK9H would not hear W9XA reply because he is not properly programmed for cross-band operation.

